

TRUCK SHUTTER ORDER FORM



ASSA ABLOY

NSW 50 Orchardleigh Street, Yennora NSW, Australia 2161
 NEWCASTLE UNIT 3, 82 Mitchell Road, Cardiff (Newcastle), Australia 2285
 QLD 181 - 185 Cobalt Street, Carole Park QLD, Australia 4300
 VIC 71 - 73 Mafra Street, Coolaroo VIC, Australia 3048
 SA 25 Circuit Court, Hendon SA, Australia 5014

Tel: (02) 9892 3188
 Tel: (02) 4956 7878
 Tel: (07) 3271 2877
 Tel: (03) 9302 3366
 Tel: (08) 8445 9002

Fax: (02) 9892 2167
 Fax: (02) 4954 6161
 Fax: (07) 3271 2284
 Fax: (03) 9302 3966
 Fax: (08) 8445 9003

Date _____ Order No. _____ Date Required _____ Contact _____ Phone _____ Fax _____

Customer _____

Invoice Address _____

Slat Profile Required

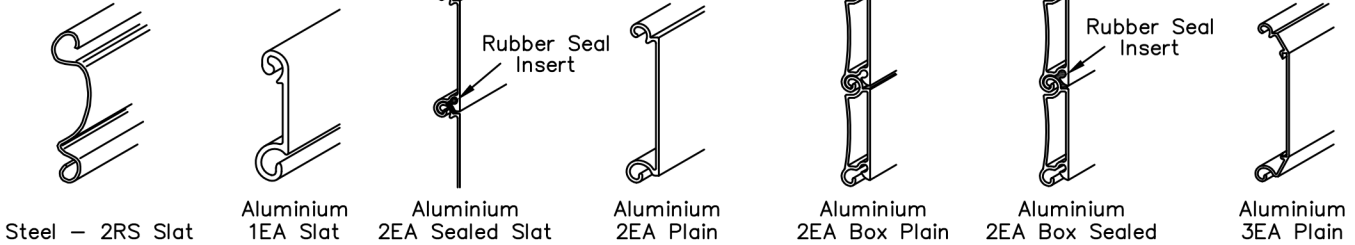

Types of Lock

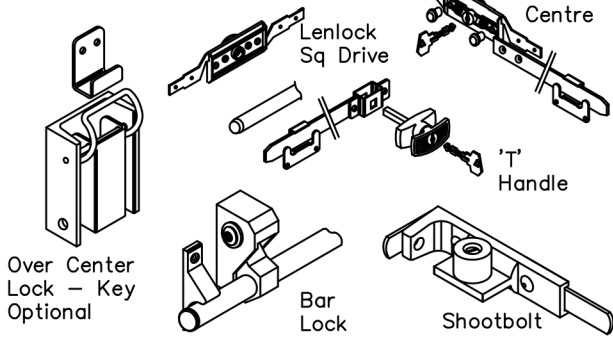

Head Seals Optional Extras

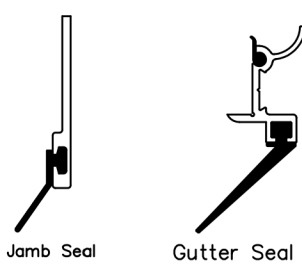

Bracket Types

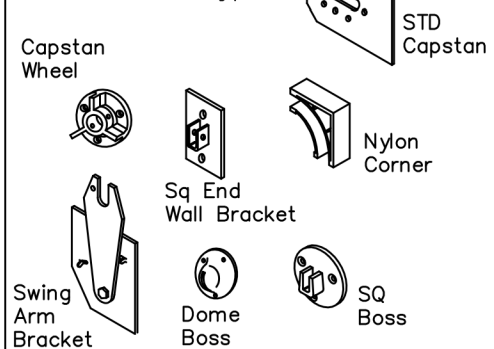

Shutter Type Required

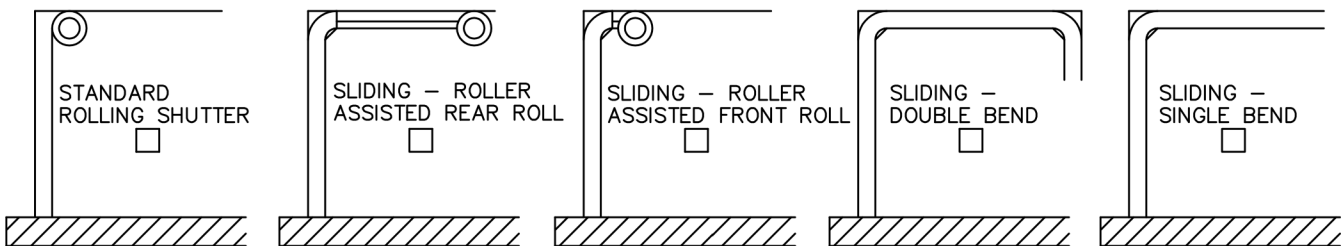

Opening Details

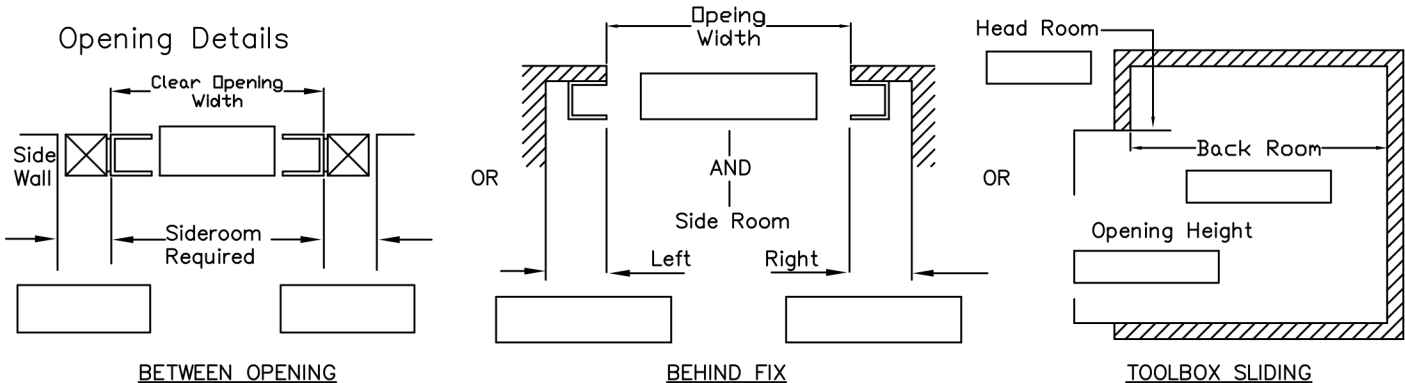

Guide Type

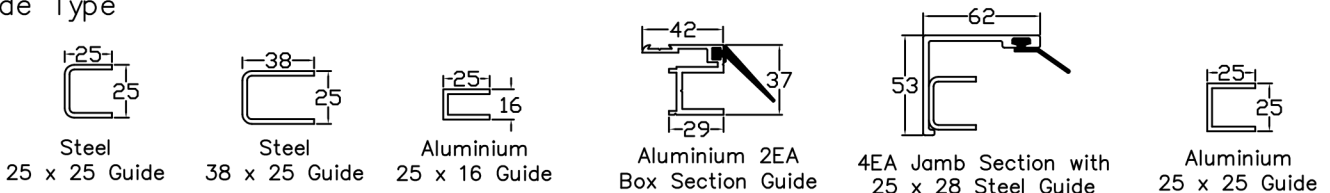

Finish Required

Galvanised Mill Finish Anodised Etch & Clear Anodised Colour Powder Coat Colour

Requirements

Door Quantity _____ Extras _____